

AL FONDERIE
LUMINIO
TAZZARI



FONDERIE ALLUMINIO TAZZARI SPA

Via Selice Provinciale 42/C
40026 - Imola (Bo), Italy

THE BEST TECHNOLOGIES FOR ALUMINIUM CASTINGS

GRAVITY SAND



GRAVITY DIE

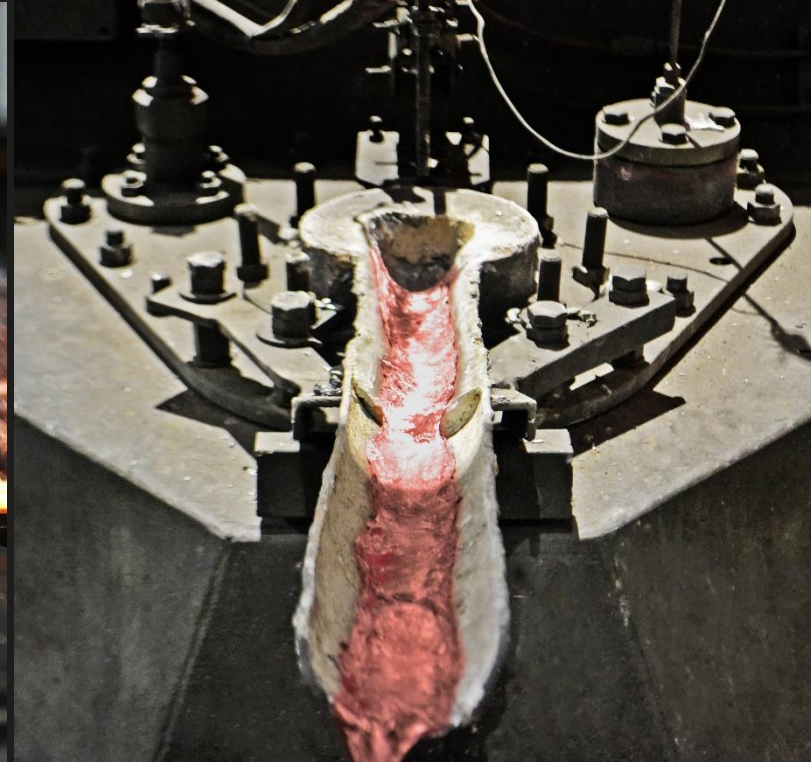

LOW PRESSURE DIE

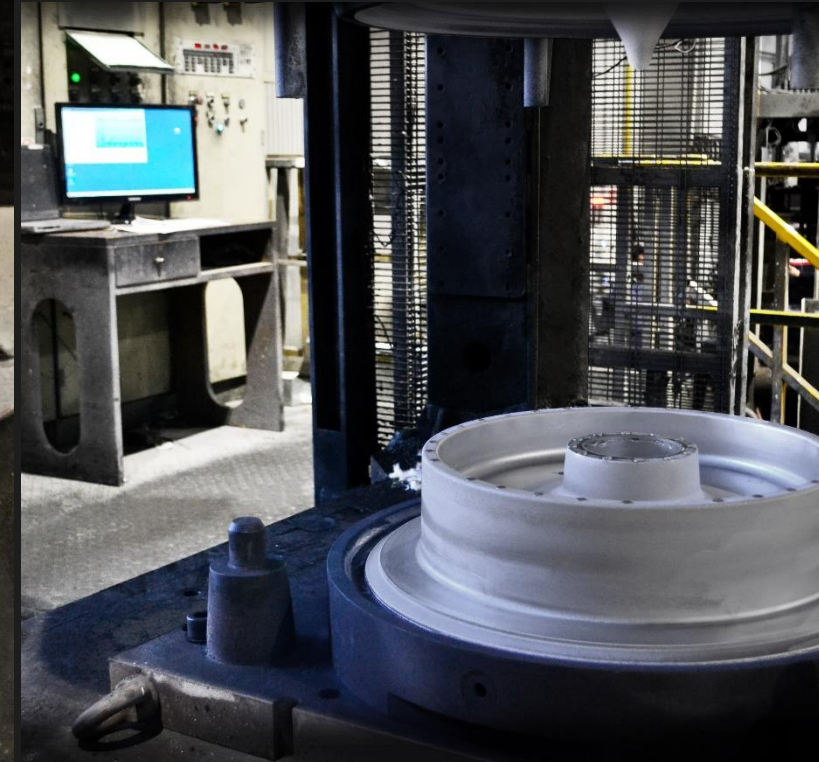

GREEN SAND



Automatic plant with 3 robots
for GREEN SAND casting
Prototypes and series
Max. Dimension: 1000 X 800
Max. Weight: 150 kg

50 castings per hour, for small and mid series.
Very flexible with small investment in tooling

SAND RESIN

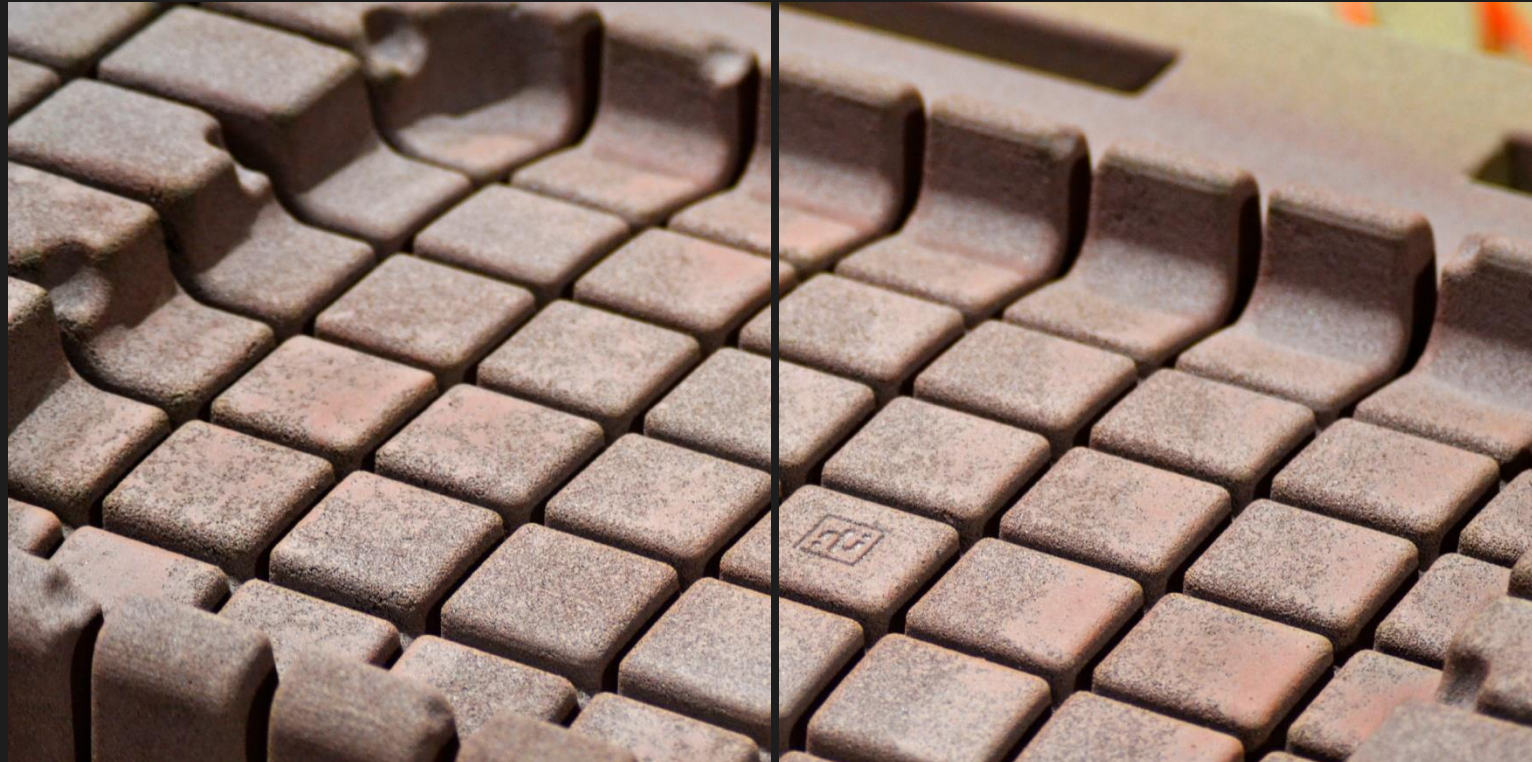

Automatic plant for RESIN SAND casting
Prototypes and series
Max. Dimension: 2000 X 1500
Max. Weight: 350 kg

6 castings per hour, for small series.
High performance for big size aluminum
castings

AUTOMATIC DOSING DIE CASTING

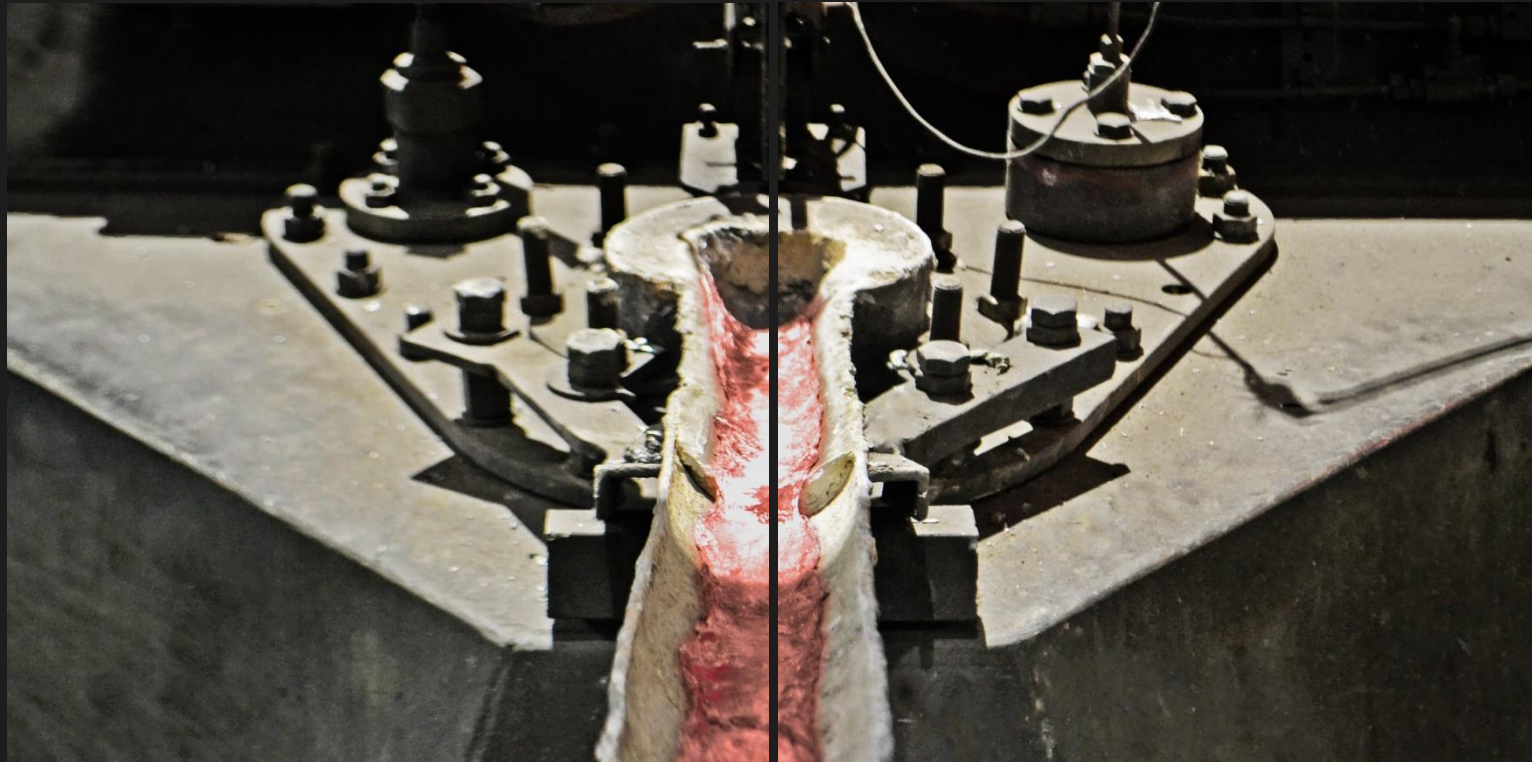

Automatic lines with dosing furnace
High volumes series
Max. Dimension: 1200 X 800
Weight: 1-100 kg

Up to 720 pieces per hour.
Complete automatic process for high series and
high quality standards.

AUTOMATIC ROBOT DIE CASTING



Automatic lines with casting robot
Mid and High volumes series
Max. Dimension: 1200 X 800
Weight: 1-50 kg

Up to 240 pieces per hour.
Complete automatic process for high series and
high quality standards.

AUTOMATIC LOW PRESSURE DIE CASTING



Automatic plants for low pressure die casting
Mid and High volumes series
Max. Dimension: 1400 x 1000
Weight: 1-100 kg

Up to 180 pieces per hour.
Automatic plants for high series,
best performance for mechanical proprieties.

FONDERIE ALLUMINIO TAZZARI SPA

INFORMATIONS

3200-4500

TONS OF **ALUMINIUM**
PRODUCED
PER YEAR

28-38

MILLIONS OF
TURNOVER

190-230

EMPLOYEES

1.3-1.8 MLN

PIECES
PRODUCED
PER YEARS

AUTOMATIC CONCEPT FOR FINISHING PROCESSES

CUTTING

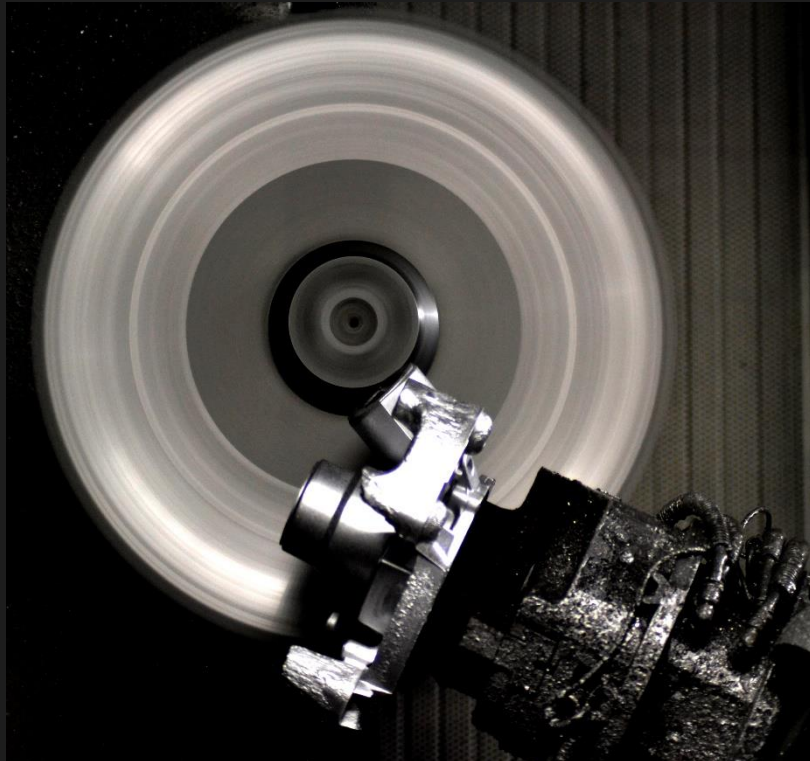

DECORING



TRIMMING

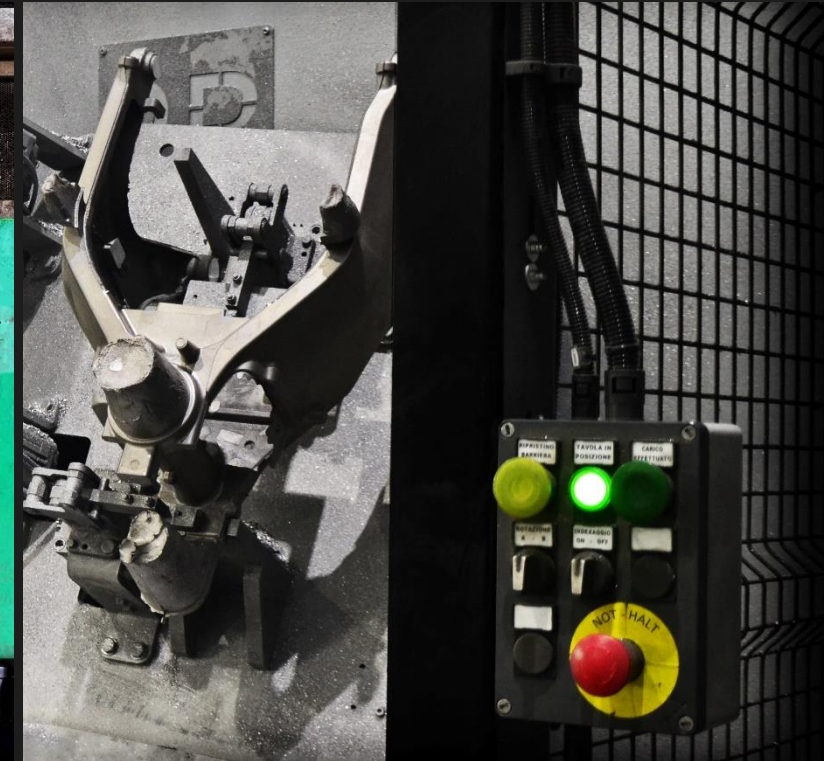

CONTROL AND PERFORMANCE WITH INTERNAL PROCESSES

PATTERN SHOP

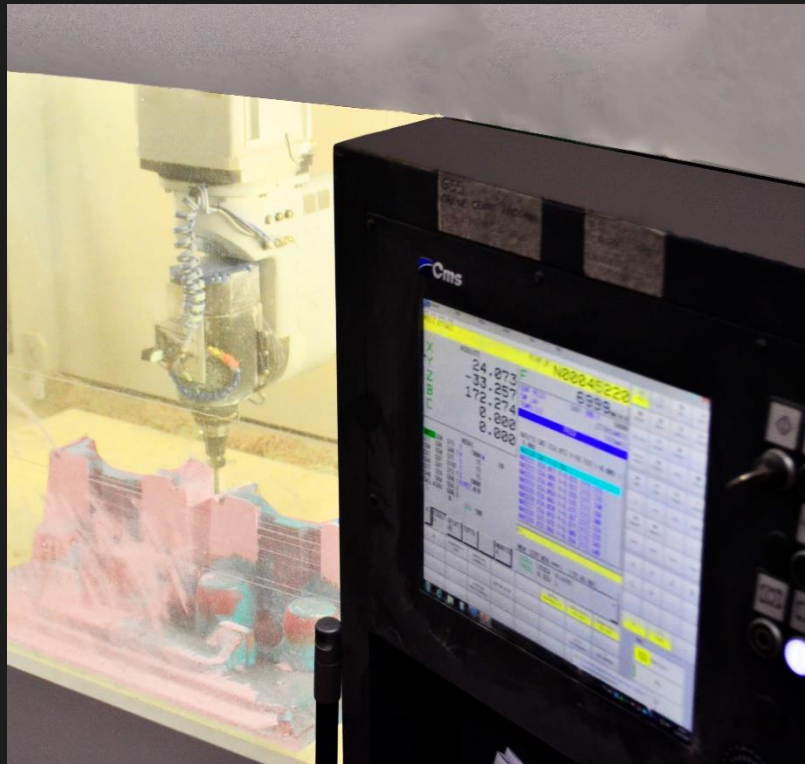

CORESHOP



HEAT TREATMENT



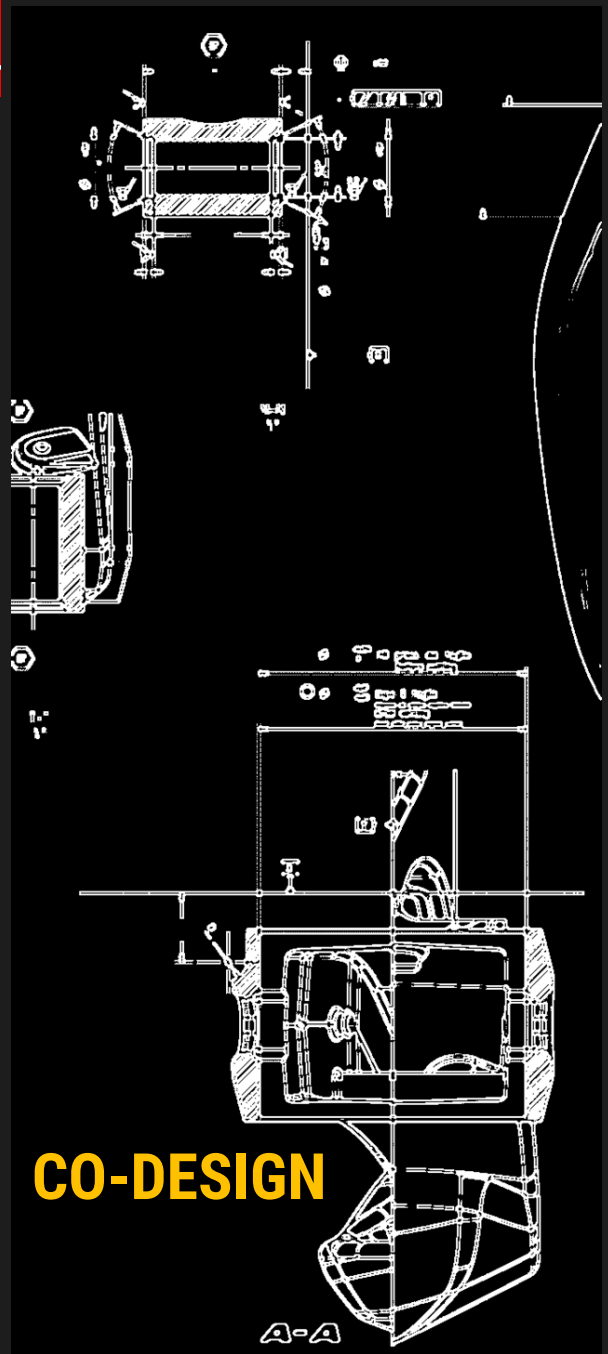

CO-DESIGN



**FROM THE
DESIGN
TO THE
COMPONENT**

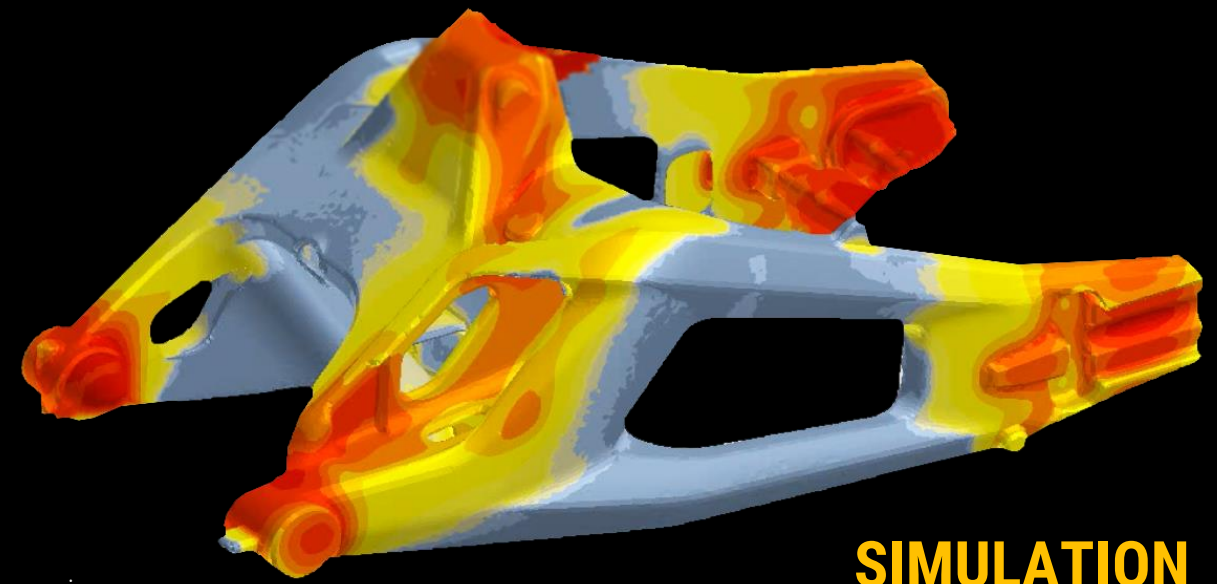

SIMULATION

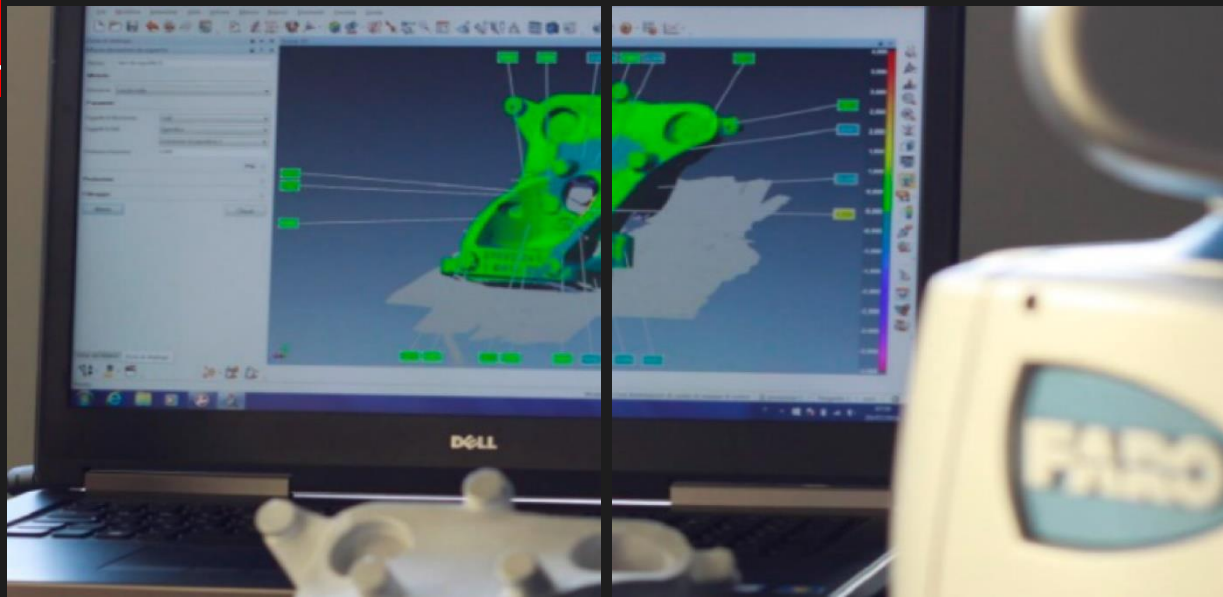

HIGH-QUALITY STANDARDS

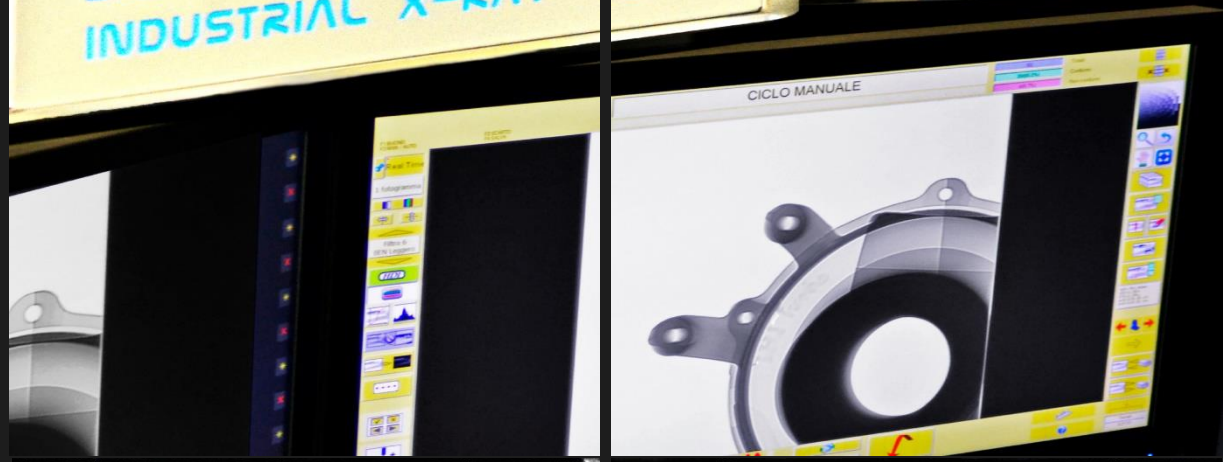
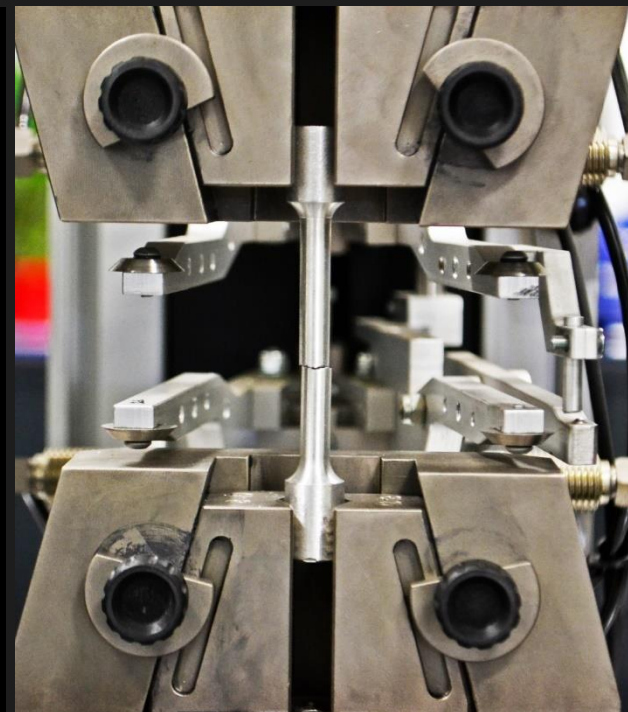

INSTRUMENTS

- FARO ARM FOR DIMENSIONAL CONTROLS
- 2 X-RAY INSPECTION MACHINES
- CT- TOMOGRAPHY
- SPECTRO FOR CHEMICAL ANALYSIS
- TENSILE TEST MECHANICAL PROPRIETIES
- MICROSCOPE FOR STRUCTURAL ANALYSIS
- HARDNESS TEST
- INTERCONNECTED FACTORY
- MANUFACTURING 4.0



FONDERIE ALLUMINIO TAZZARI SPA

HIGH PERFORMANCE FOR ALUMINIUM COMPONENTS

**MOTORCYCLE
COMPONENTS**

**AUTOMOTIVE
COMPONENTS**

**MARINE/NAVAL
COMPONENTS**

**LIFTS
COMPONENTS**

COMPONENTS FOR
ELECTRIC ENGINES
DIESEL ENGINES
PUMPS
AGRICULTURE
TRUCKS
HEAT EXCHANGER
GEAR BOXES
RENEWABLE ENERGIES
MANY OTHERS

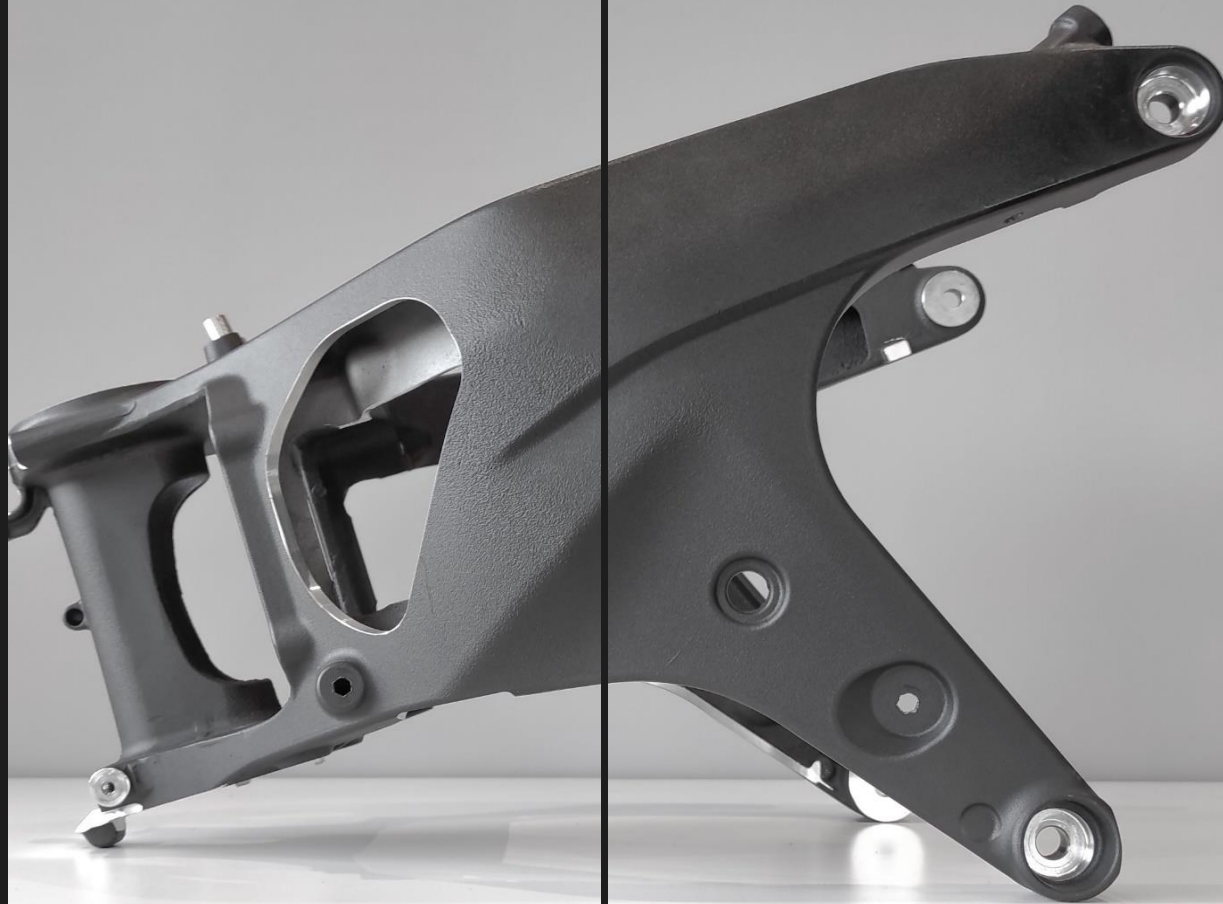

PANIGALE V4

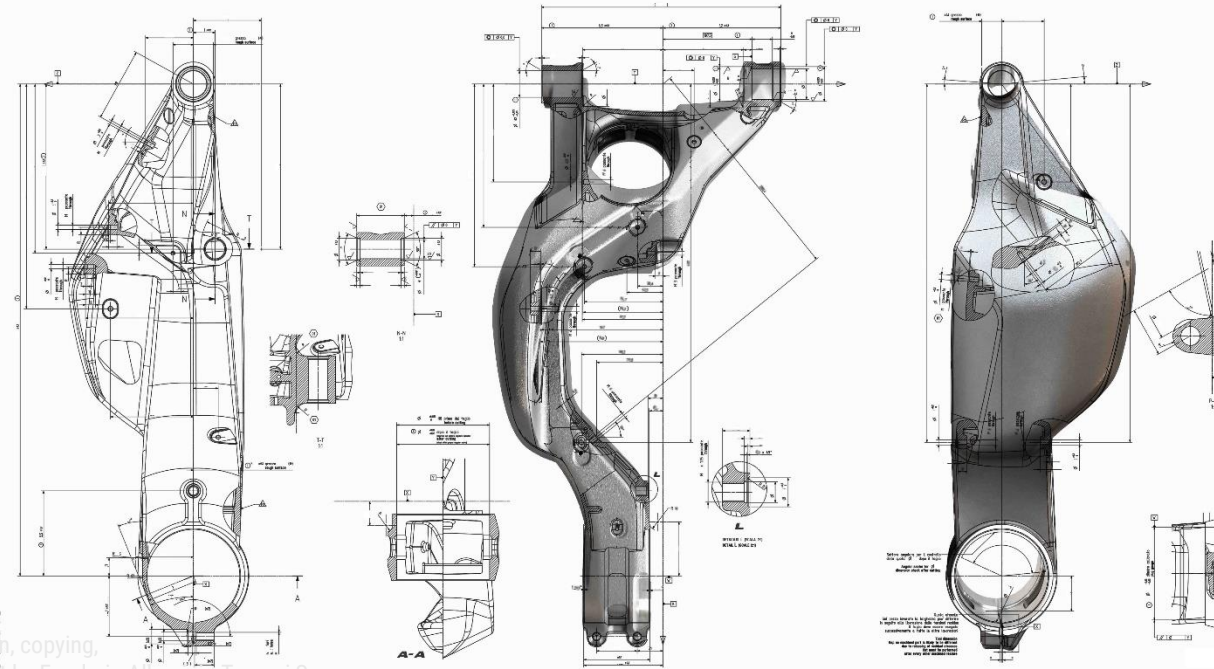



STREETFIGHTER V4

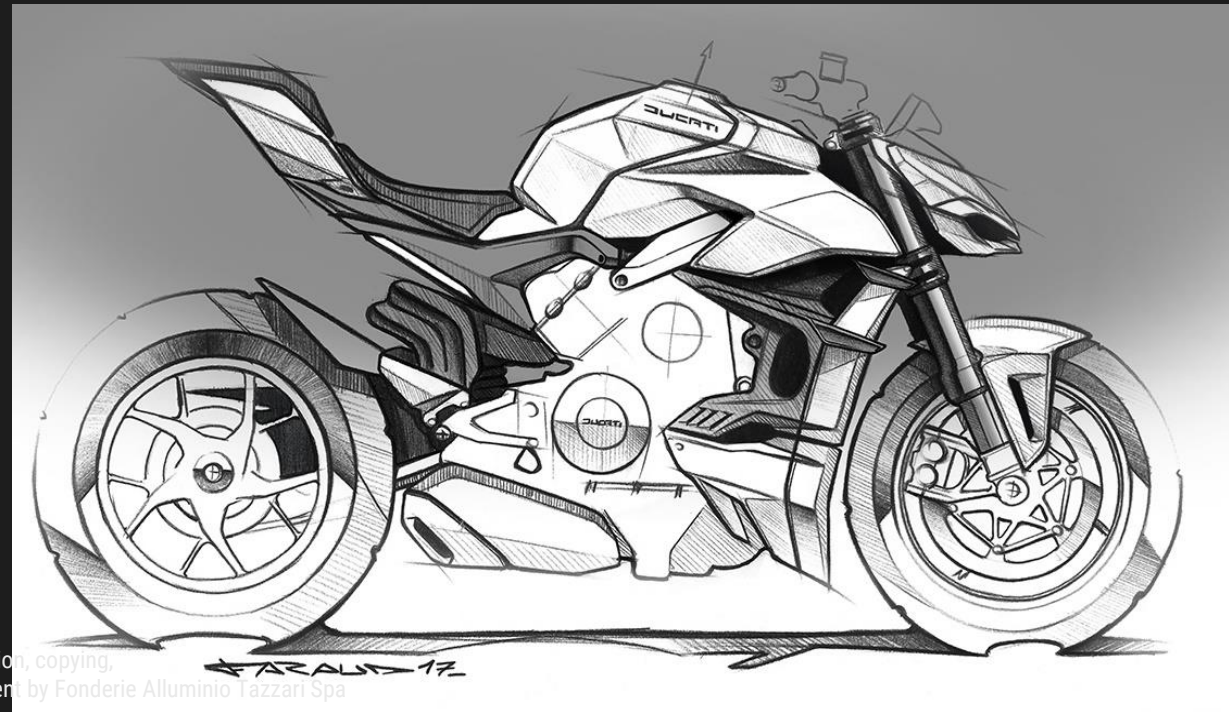
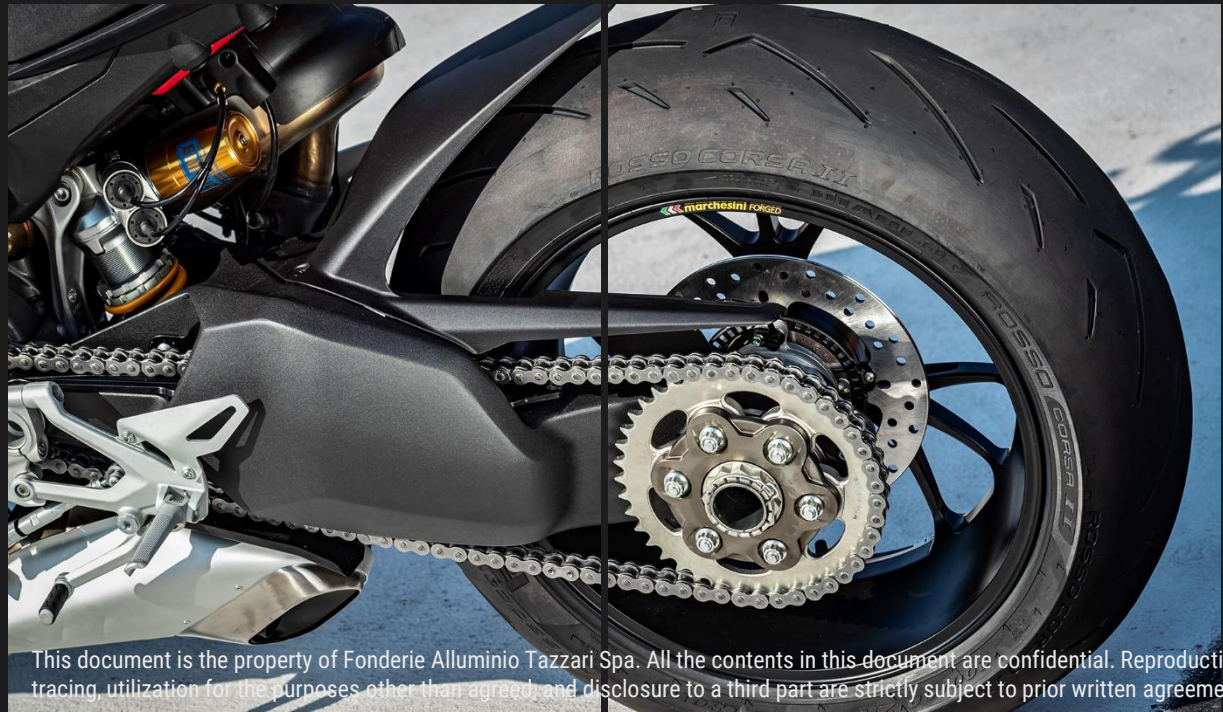

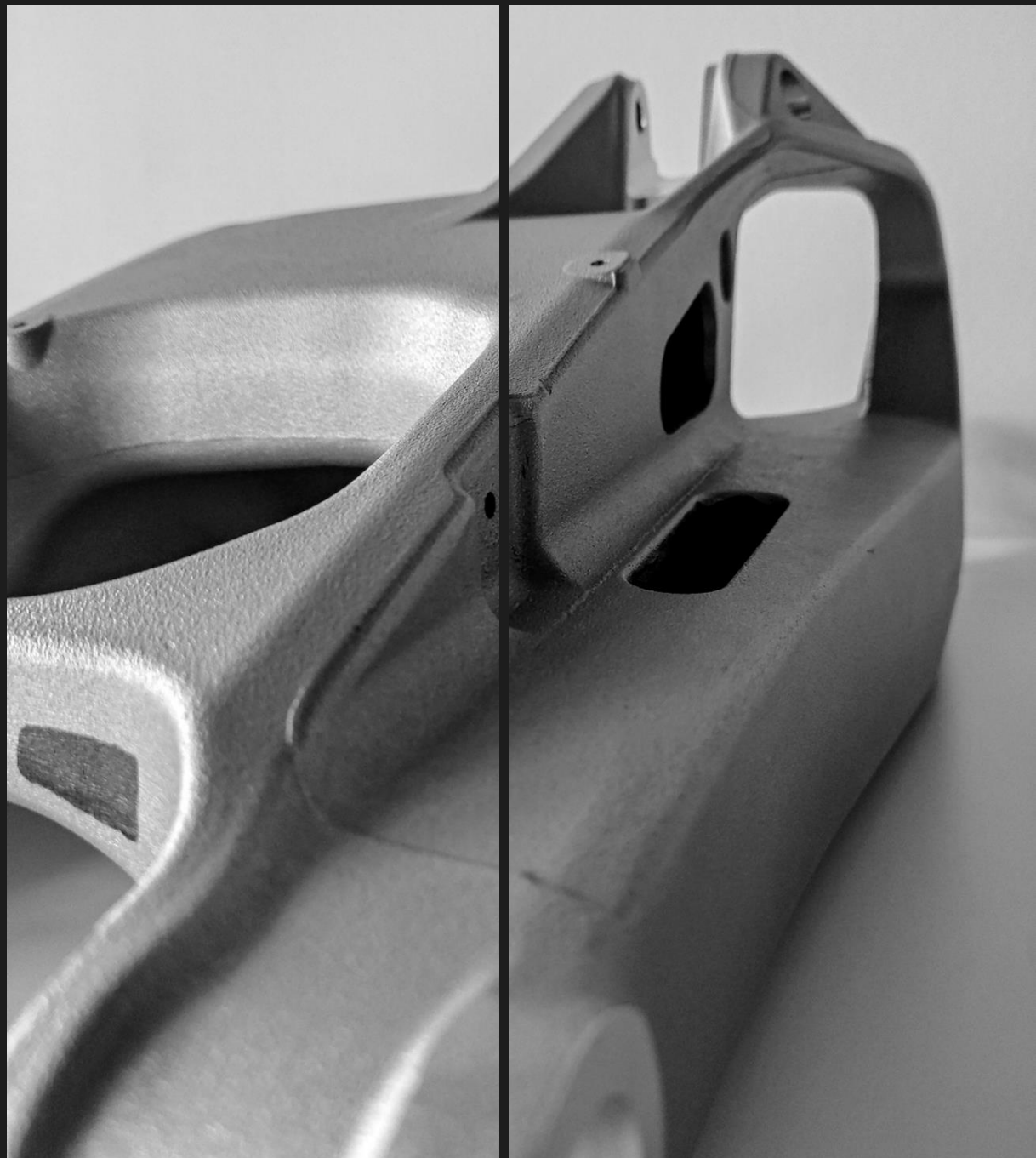

MULTISTRADA

V4



MULTISTRADA

1260
950
ENDURO

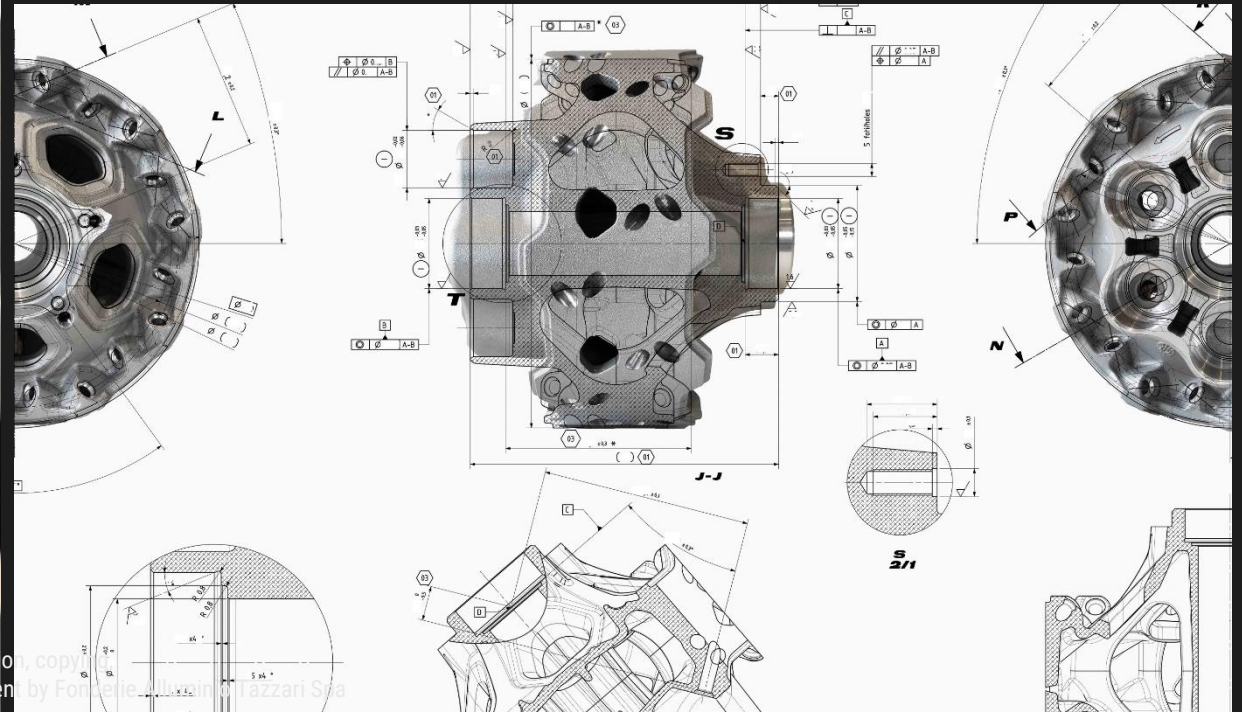
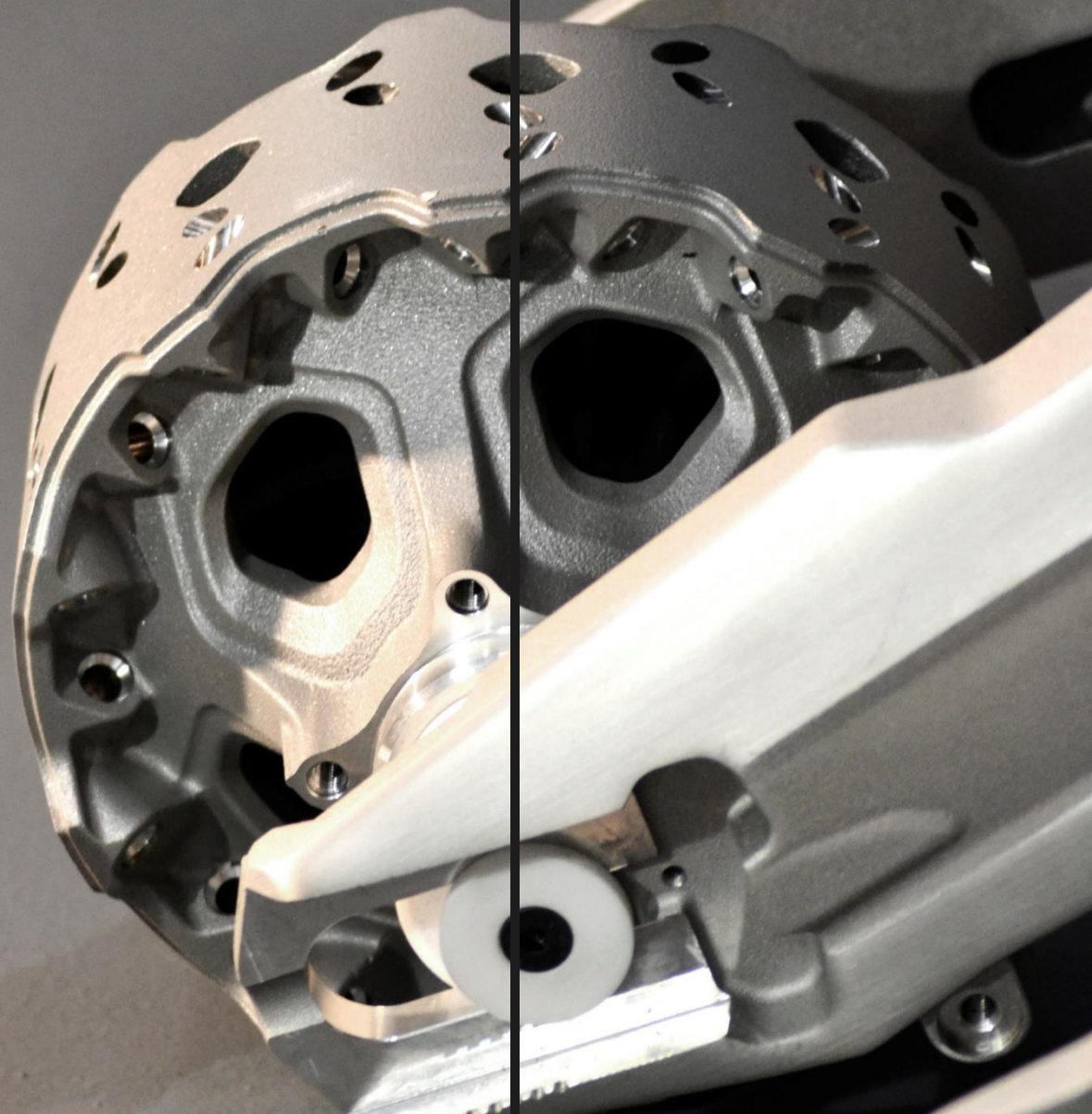



X-DIAVEL





MV AUGUSTA

BRUTALE
TURISMO VELOCE
RIVALE
SUPERVELOCE





MV AUGUSTA

SUPERVELOCE

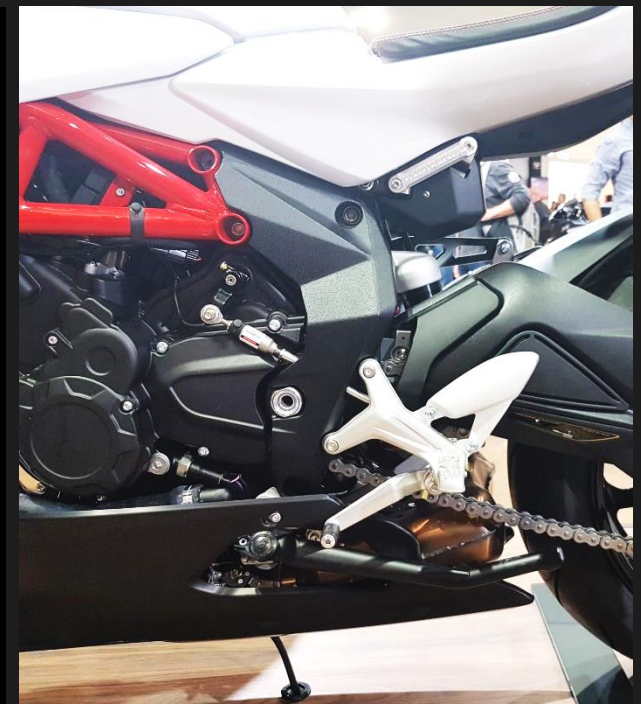



ALFA ROMEO QUADRIFOGLIO

GIULIA
STELVIO

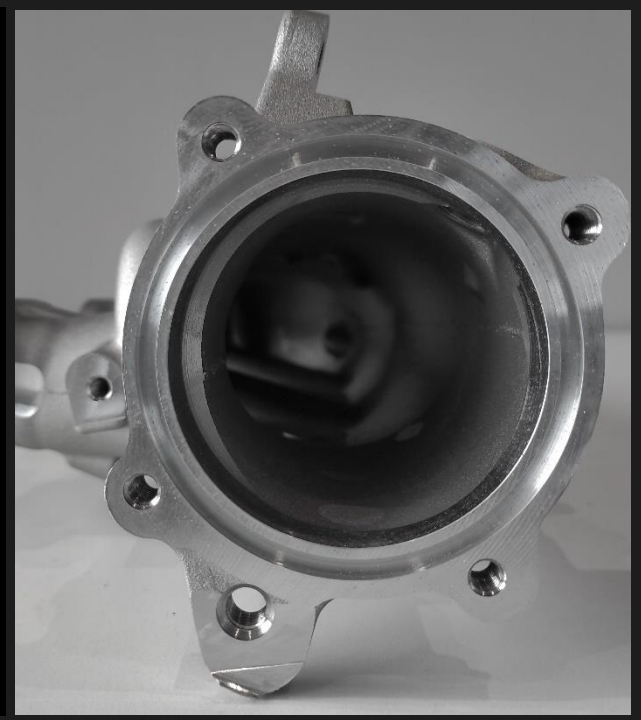



MASERATI

LEVANTE

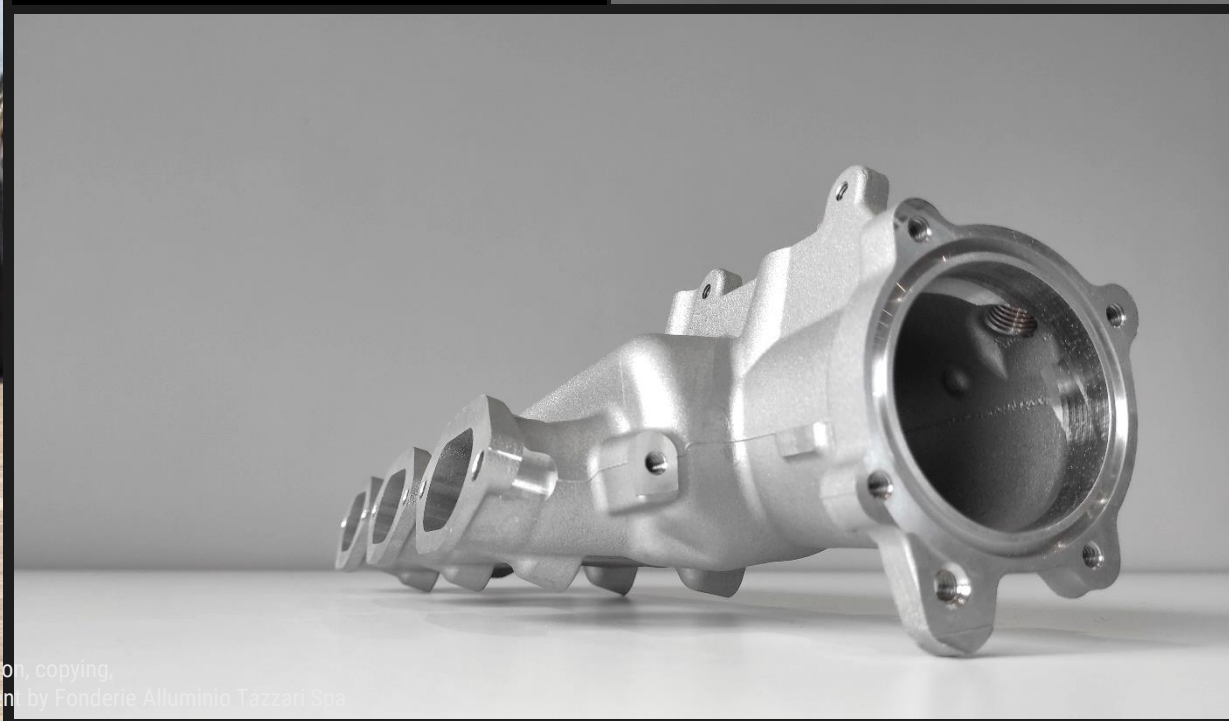
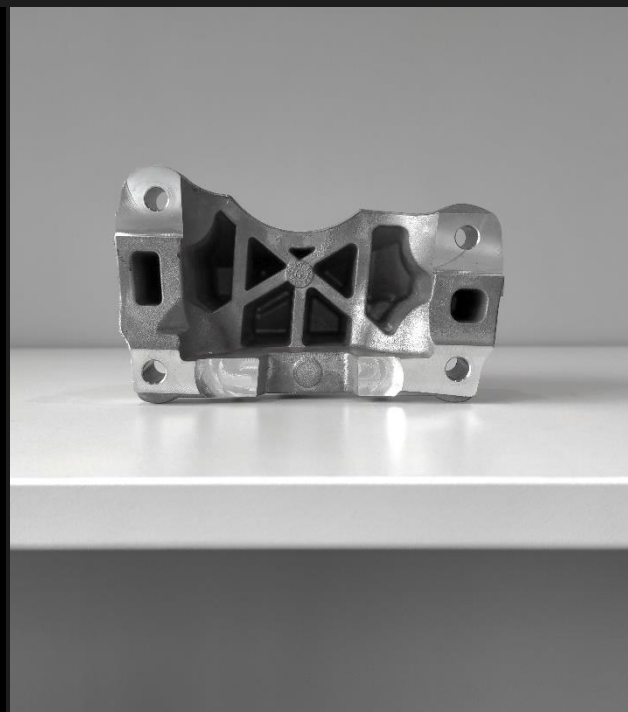

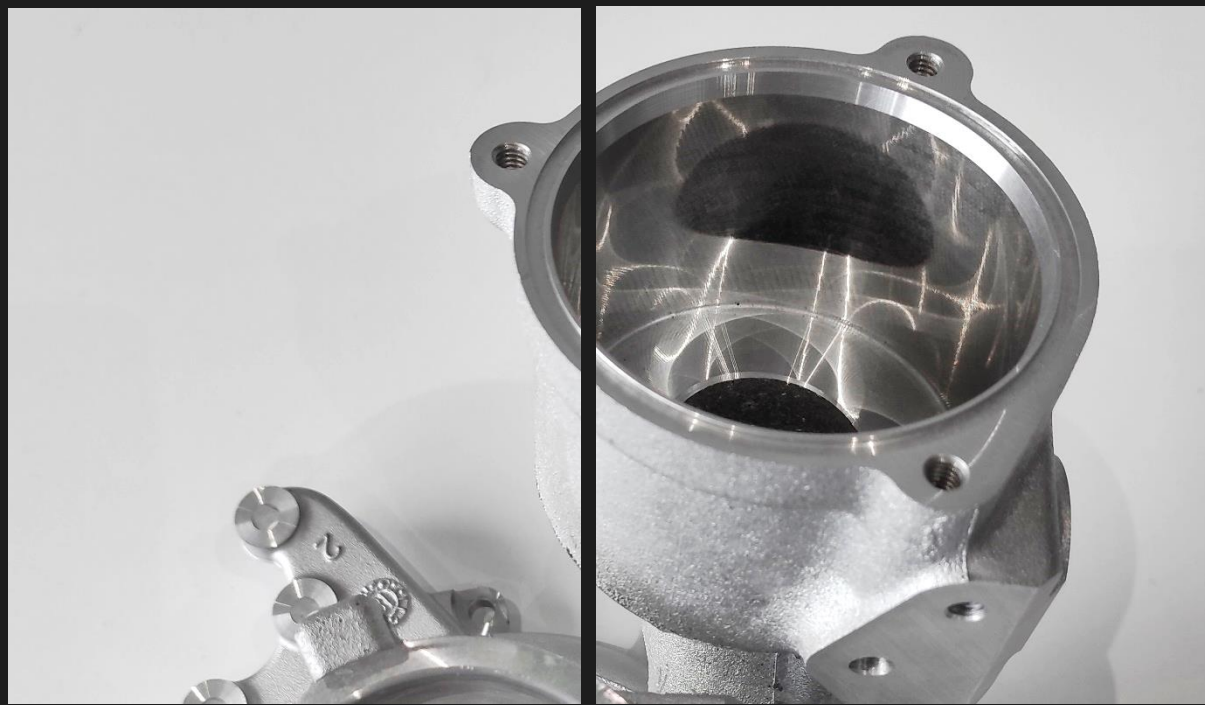

IHI
TURBO COMPONENTS

IHI CHARGING SYSTEMS
INTERNATIONAL

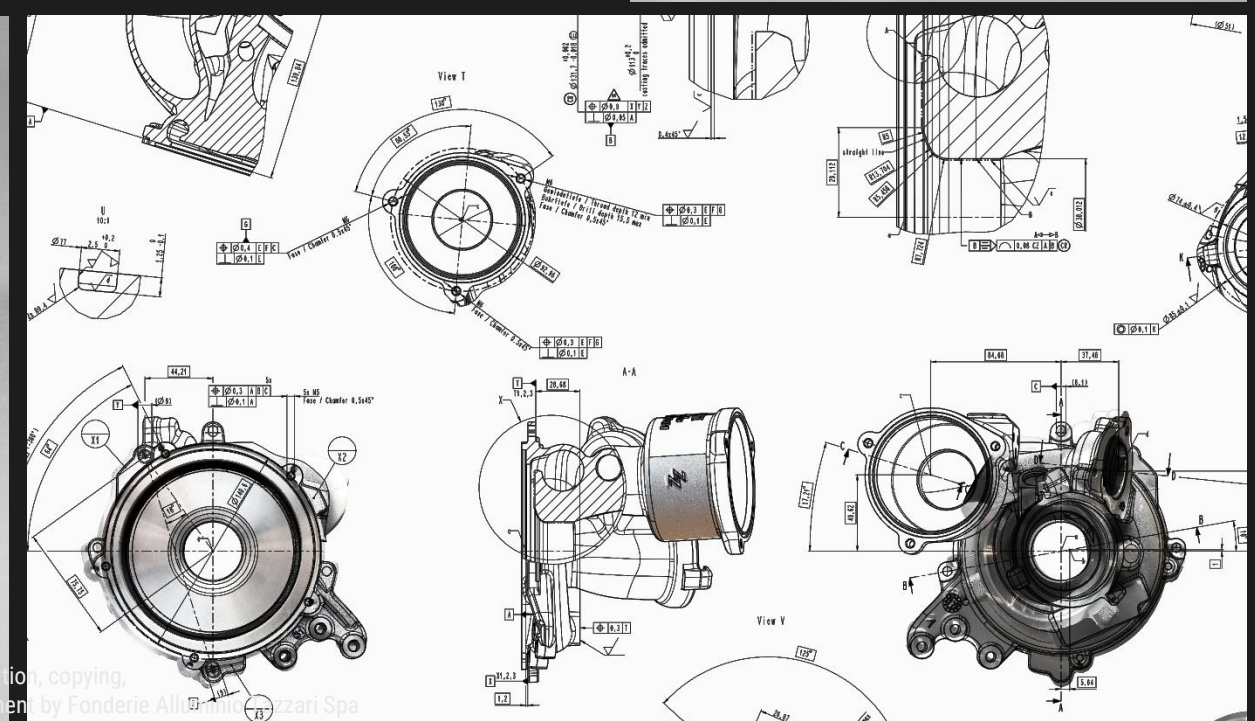
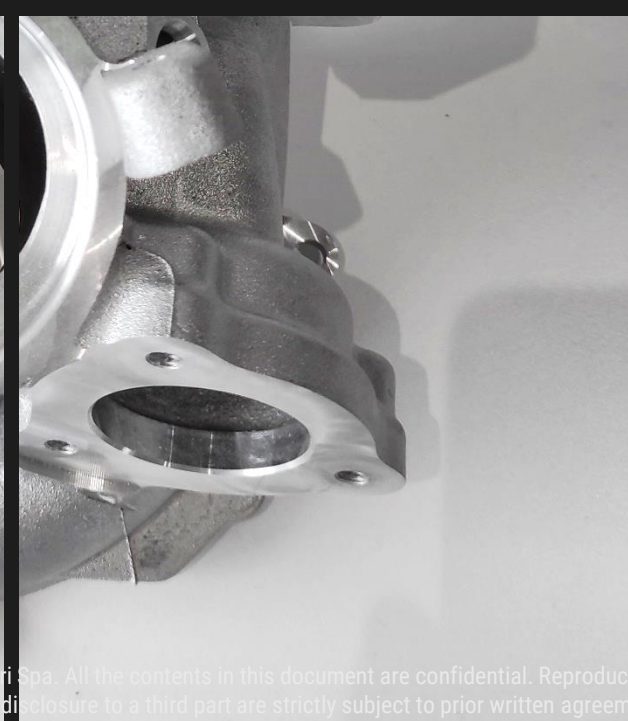
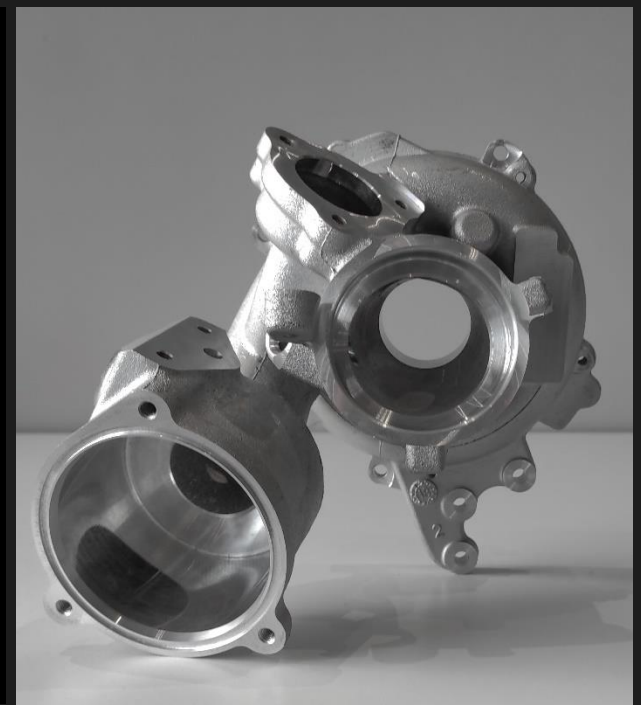



MAN
TRUCKS

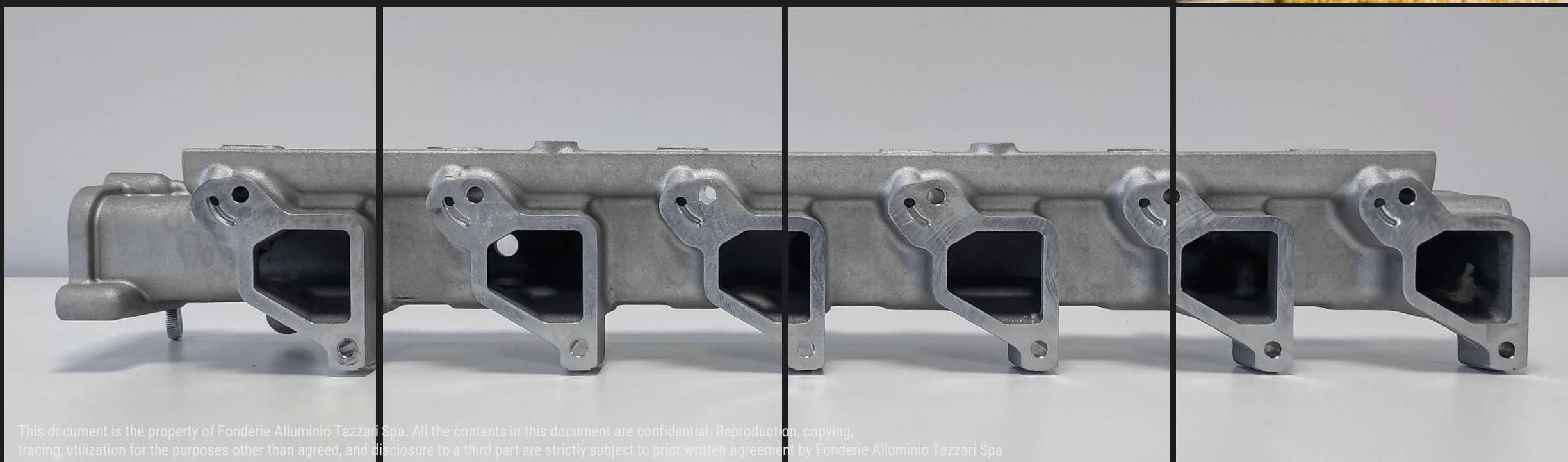

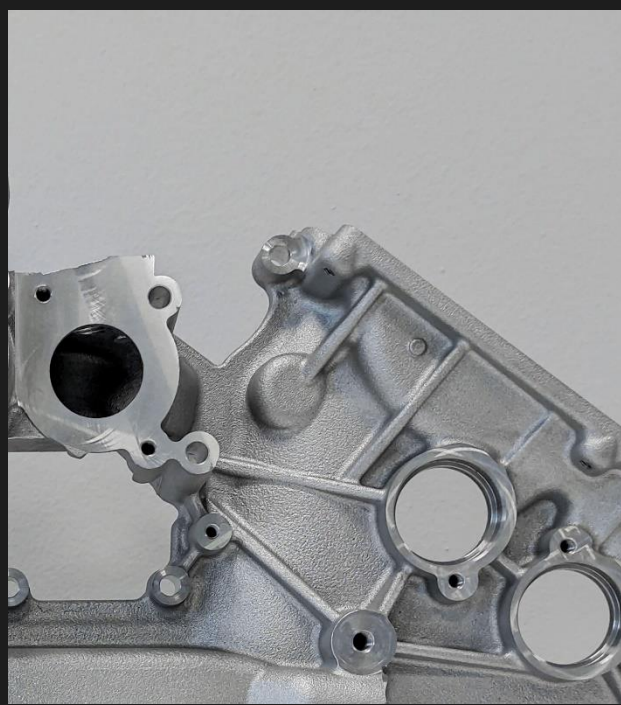
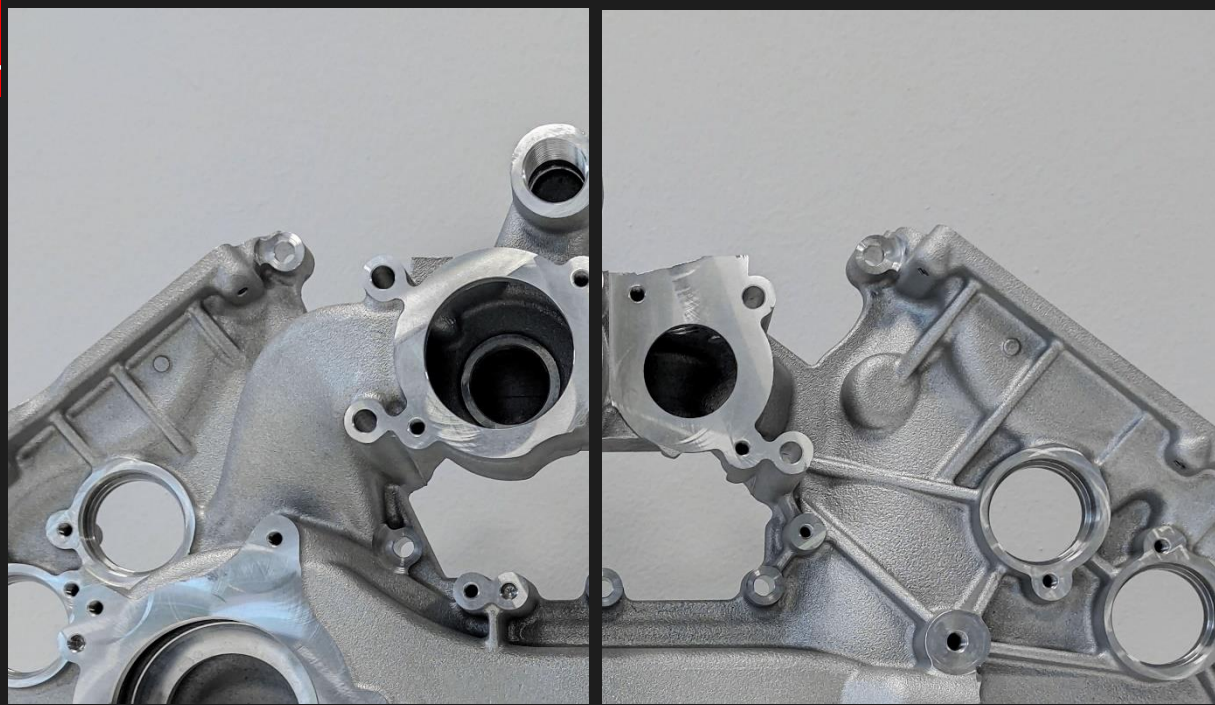

MAN
TRUCKS

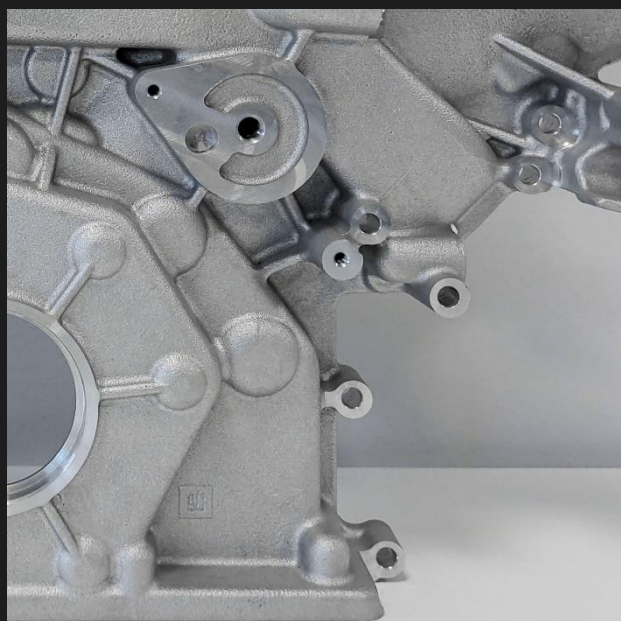
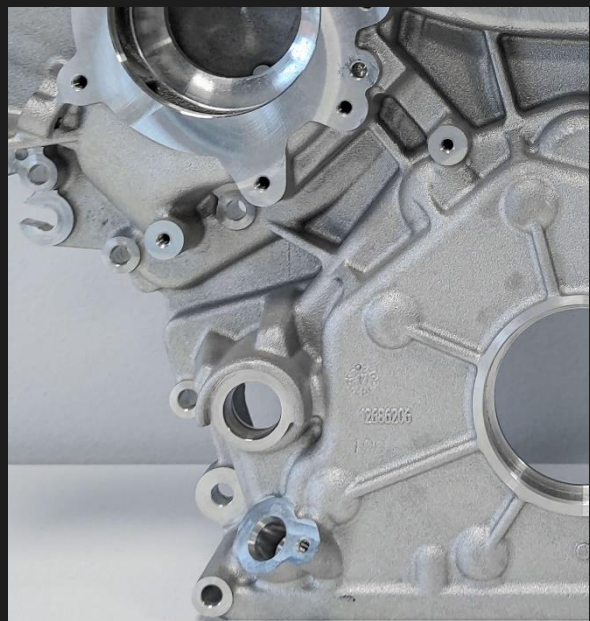
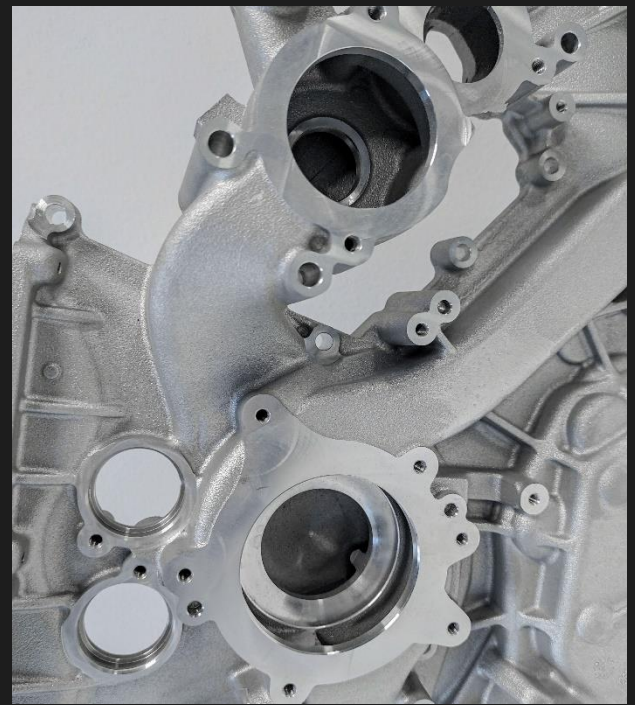



ZF GROUP

NAVAL
TRUCKS
AUTOMOTIVE

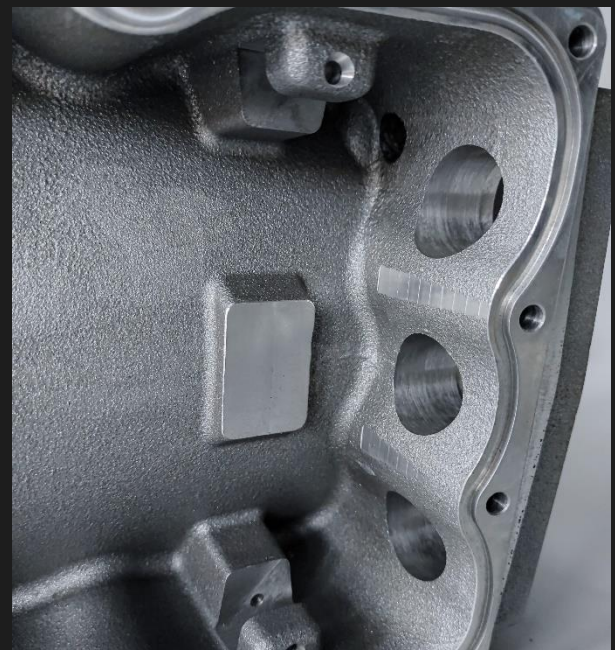
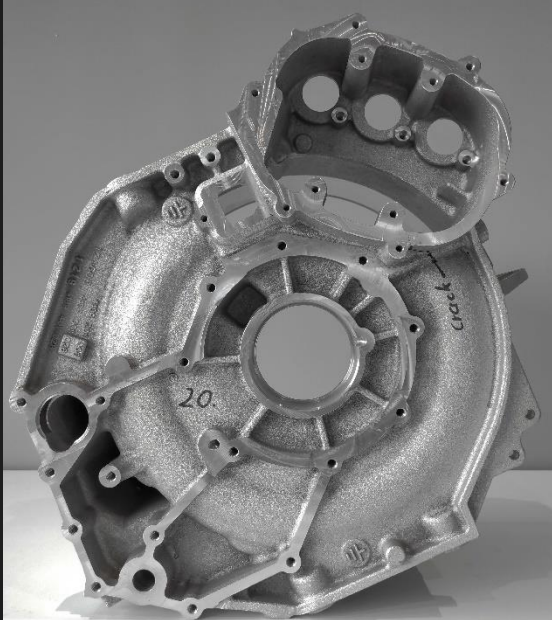



OTHERS
ELETRIC ENGINES
DIESEL ENGINES
PUMPS
AGRICOLTURE
HEAT EXCHANGER
GEAR BOXES
RENEWABLE ENERGIES
MANY OTHERS

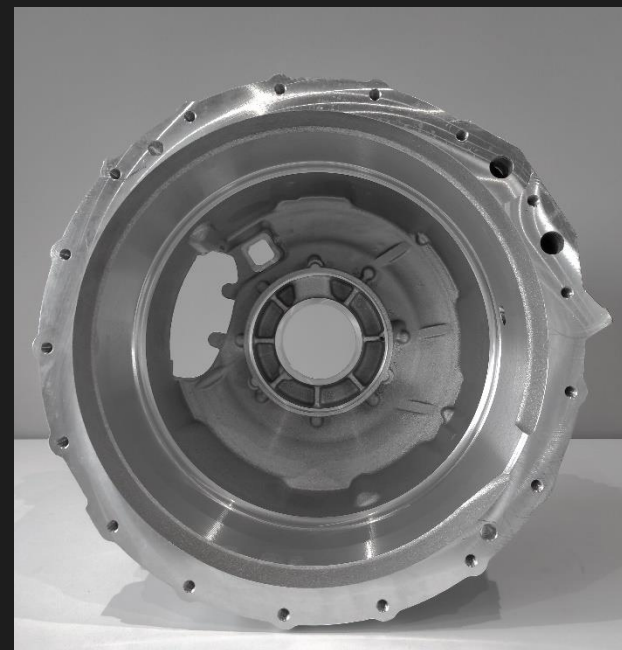

FONDERIE ALLUMINIO TAZZARI SPA

CONTACTS

Telephone

+39 0542 689011

E-Mail

info@tazzari.it

Location

Via Selice Provinciale 42/C
40026 - Imola (Bo)
Italia

